

BUTTERFLY VALVE TYPE 56D,75D Type56D:400mm(16inch) Type75D:450mm·600mm(18inch·24inch)



FEATURES

Easy Transformation of Operation Devices

Application of modular design on top flange provides the valve with flexible and easy change of operation types, and from manual to automatic and so on.

Option

Long stem type and chain drive type are available on special request.

SPECIFICATIONS

Body material	Disc material	Nominal size mm(inch)	Working Temperature °C (°F)	Max. Working Pressure (at R.T.) MPa[kgf/cm ²][PSI]
PDCPD	PP	400(16)~600(24)	0 - 90(30 - 195)	0.75{7.7}[110]
	PVDF	400(16)~600(24)	0 - 100(30 - 210)	0.75{7.7}[110]

※R.T.···Room Temperature

PARTS & MATERIALS

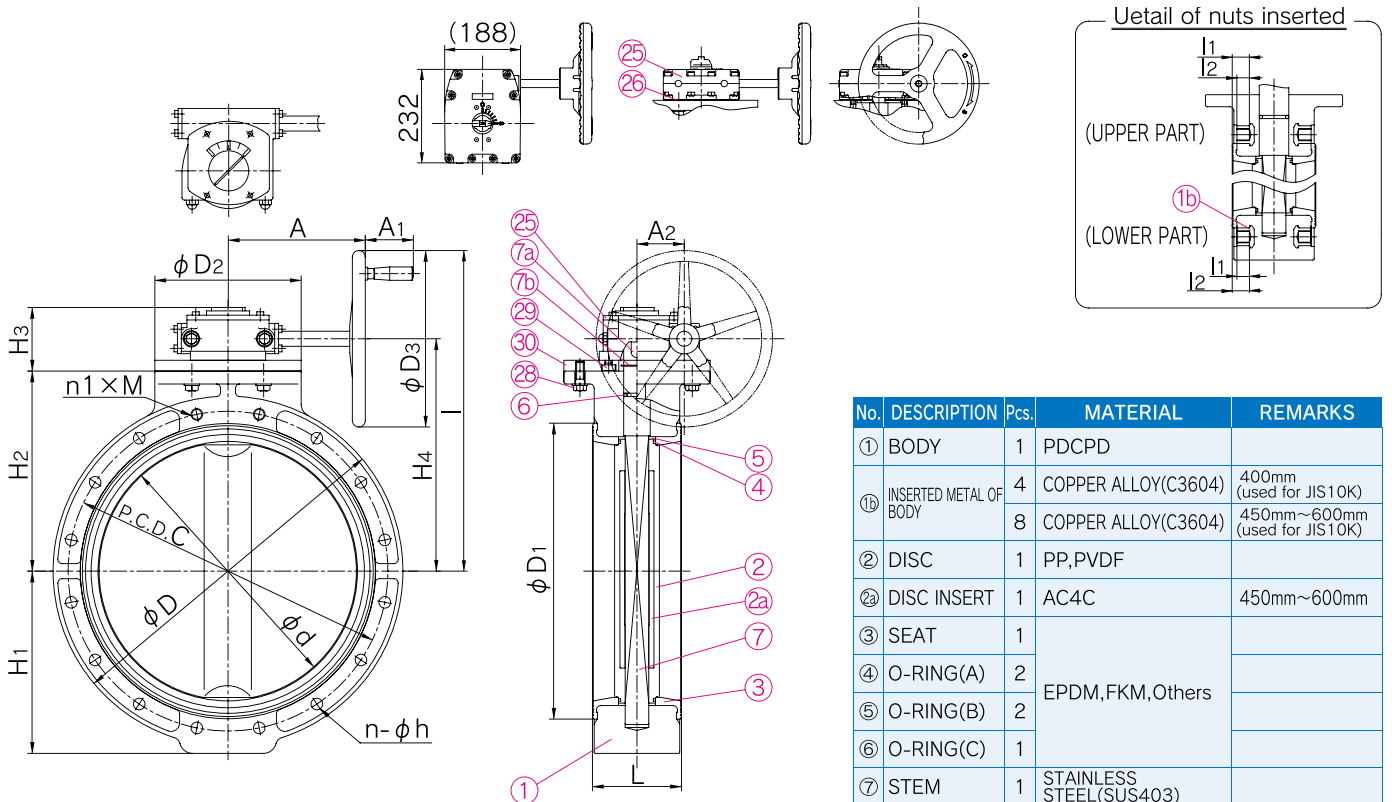

No.	DESCRIPTION	Pcs.	MATERIAL	REMARKS
①	BODY	1	PDCPD	
1b	INSERTED METAL OF BODY	4	COPPER ALLOY(C3604)	400mm (used for JIS10K)
		8	COPPER ALLOY(C3604)	450mm~600mm (used for JIS10K)
②	DISC	1	PP,PVDF	
2a	DISC INSERT	1	AC4C	450mm~600mm
③	SEAT	1	EPDM,FKM,Others	
④	O-RING(A)	2		
⑤	O-RING(B)	2		
⑥	O-RING(C)	1		
⑦	STEM	1	STAINLESS STEEL(SUS403)	
7a	KEY(A)	1	CARBON STEEL(S45C)	
7b	SNAP RING	1	STAINLESS STEEL(SUS304)	450mm
25	GEAR BOX	1	PLASTIC etc.	400mm
26	GASKET(A)	1	CAST ALUMINIUM ALLOY FC250(epoxy coat)	450mm~600mm
28	BOLT (C)	4	EPDM	400mm
29	BOLT (D)	4	STAINLESS STEEL(SUS304)	
30	STAND	1	STAINLESS STEEL(SUS304)	
30	STAND	1	STEEL(SS400)	

NOM. SIZE	M	BOLT HOLES n	Q'TY OF INSERTED NUT			l ₁	l ₂
			UPPER	LOWER	TOTAL (2×n1)		
400 16	M24	14	2×2	—	4	36	24
450 18	M24	16	2×2	2×2	8	36	24
500 20	M24	16	2×2	2×2	8	36	24
600 24	M30	20	2×2	2×2	8	43	30

WORKING PRESSURE VS. TEMPERATURE

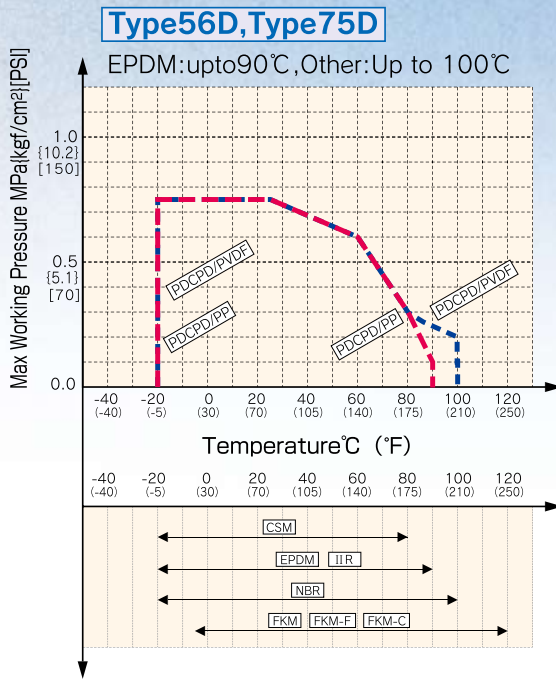

DIMENSIONS TABLE

JIS																				Unit:mm		
Nominal Size	d	JIS 10K						D	D ₁	D ₂	D ₃	L	H ₁	H ₂	H ₃	H ₄	I	A	A ₁	A ₂	Number of handle rotation	GEAR BOX MODEL No.
		C	n	h	n ₁	M																
400	16	406	510	14	27	2	M24	620	470	235	300	169	315	350	108	390	540	272	—	99.2	9.5	TYPE3
450	18	452	565	16	27	4	M24	665	525	340	410	179	335	370	139	445	650	319	85	110	17	BVG-2H
500	20	502	620	16	27	4	M24	720	575	340	410	190	365	400	139	475	680	319	85	110	17	
600	24	603	730	20	33	4	M30	813	686	340	410	209	424	465	139	540	745	319	85	110	17	

DIN																				Unit:mm	
Nominal Size	d	DIN PN 10				D	D ₁	D ₂	D ₃	L	H ₁	H ₂	H ₃	H ₄	I	A	A ₁	A ₂	Number of handle rotation	GEAR BOX MODEL No.	
		C	n	h																	
400	16	406	515	16	26	620	470	235	300	169	315	350	108	390	540	272	—	99.2	9.5	TYPE3	
450	18	452	565	20	26	665	525	340	410	179	335	370	139	445	650	319	85	110	17	BVG-2H	
500	20	502	620	20	26	720	575	340	410	190	365	400	139	475	680	319	85	110	17		
600	24	603	725	20	30	813	686	340	410	209	424	465	139	540	745	319	85	110	17		

ANSI																				Unit:inch	
Nominal Size	d	ANSI Class 150				D	D ₁	D ₂	D ₃	L	H ₁	H ₂	H ₃	H ₄	I	A	A ₁	A ₂	Number of handle rotation	GEAR BOX MODEL No.	
		C	n	h																	
16	400	15.98	21.26	16	1.12	24.41	18.50	9.25	11.81	6.65	12.40	13.78	4.25	15.35	21.26	10.70	—	3.91	9.5	TYPE3	
18	450	17.80	22.76	20	1.26	26.18	20.67	13.39	16.14	7.05	13.19	14.57	5.47	17.52	25.59	12.56	3.35	4.33	17	BVG-2H	
20	500	19.76	25.00	20	1.26	28.35	22.64	13.39	16.14	7.48	14.37	15.75	5.47	18.70	26.77	12.56	3.35	4.33	17		
24	600	23.74	29.53	20	1.38	32.01	27.01	13.39	16.14	8.23	16.69	18.31	5.47	21.26	29.33	12.56	3.35	4.33	17		