

PDCPD BUTTERFLY VALVE 700mm - 1200mm(28inch - 48inch)



Nominal Size
700mm - 1200mm
(28inch - 48inch)

FEATURES

High Corrosion Resistance

The body and disc are made of PDCPD. And the corrosion-resistant resin, covering the whole contact surface, makes the valve highly resistant against chemical and sea water.

Light Weight

PDCPD having 1/4 or less the specific gravity of iron, the PDCPD BUTTERFLY VALVE is significantly lighter than a metallic butterfly valve.

Tight Seal

A seat made of a synthetic rubber, makes the valve highly water-tight.

Excellent Flow Characteristics

Being concentric and streamlined, the disc gives small resistance to a flow, thus allowing it to be laminar. The seat is kept clean, since it is integrated with the entire internal wall of the body.

Easy to Install

The seat is flanged, so that it needs no gasket. The PDCPD BUTTERFLY VALVE is so light that it is easy install.

Economics

Because of its high corrosion resistance, the PDCPD BUTTERFLY VALVE remains easy to operate after prolonged periods of use and needs little maintenance. Its light weight reduces piping costs.

DIMENSION

700mm - 1000mm(28inch - 40inch)

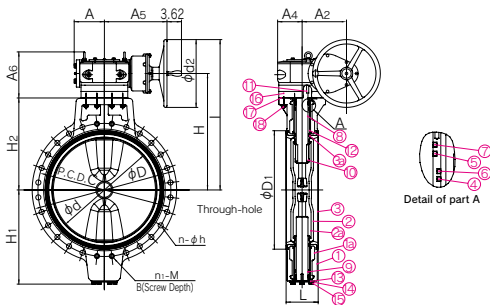

1100mm, 1200mm(44inch, 48inch)

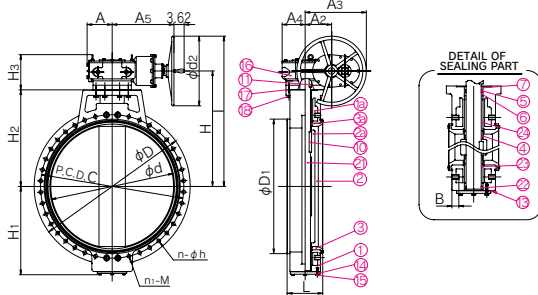

PARTS & MATERIALS

No.	DESCRIPTION	Pcs.	MATERIAL
①	BODY	1	PDCPD
②	DISC	1	PDCPD
③	SEAT	1	
④	O-RING (A)	11	EPDM
⑤	O-RING (B)	3	
⑥	O-RING (C)	1	NBR
⑦	O-RING (D)	1	NBR
⑧	STEM (A)	1	STAINLESS STEEL (SUS403)
⑨	STEM (B)	1	STAINLESS STEEL (SUS403)
⑩	KEY (A)	1	CARBON STEEL (S45C)
⑪	KEY (B)	1	CARBON STEEL (S45C)
⑫	BUSH	2	BRONZE CAST (BC6)
⑬	GASKET (A)	1	NONAS SHEET
⑭	STEM HOLDER	1	STAINLESS STEEL (SUS304)
⑮	BOLT (A)	6	STAINLESS STEEL (SUS304)
⑯	GEAR BOX	1	CASTIRON (FC200) etc.
⑰	GASKET (B)	1	NONAS SHEET
⑱	BOLT (B)	8	STAINLESS STEEL (SUS304)
⑲	STEM	1	STAINLESS STEEL (SUS304)
⑳	THRUST	1	BRONZE CAST (BC6)
㉑	BUSH (A)	1	BRONZE CAST (BC6)
㉒	BUSH (B)	1	BRONZE CAST (BC6)
㉓	INSERT METAL OF BODY	1	CAST IRON (FCD450)
㉔	INSERT METAL OF DISC	1	CAST IRON (FCD450)
㉕	INSERT METAL OF RING	2	STAINLESS STEEL (SUS304)

APPLICATIONS

Irrigation facilities, water supply and sewerage systems, heat accumulators, seawater, air pipelines, etc.

SPECIFICATIONS

Body material	Body & Disc=PDCPD. Seat=EPDMetc.
Nominal Size	700mm(28inch) - 1200mm(48inch)
Max. Working Pressure	0.75Mpa{7.7kg/cm ² } [110PSI]
Working Temperature	70 - 1000mm(28inch - 40inch) 0 - 80°C (30° F - 176° F) 1100, 1200mm(44inch - 48inch) 0 - 60°C (30° F - 140° F)

WORKING PRESSURE VS. TEMPERATURE

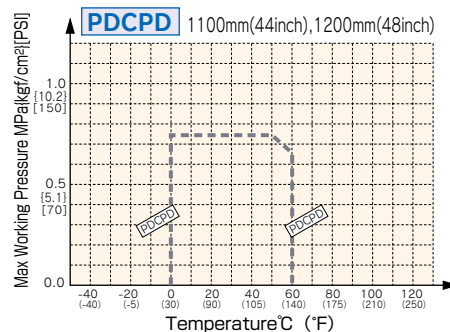
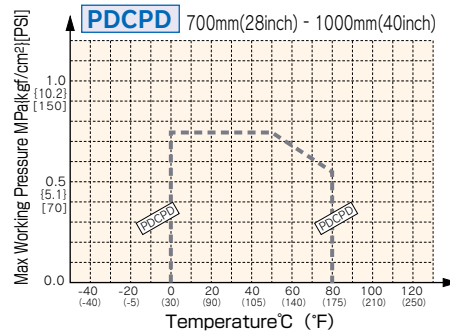

LIST OF FLANGE STANDARDS

Nominal Size mm(inch)	FLANGE STANDARDS			Max. Working Pressure
	JIS 10K	ANSI Class 150	DIN PN10	MPa {kgf/cm ² } [PSI]
700(28)	○	○	○	0.75 {7.7} [110]
800(32)	○	○	○	0.75 {7.7} [110]
900(36)	○	—	○	0.75 {7.7} [110]
1000(40)	○	○	○	0.75 {7.7} [110]
1100(44)	○	○	—	0.75 {7.7} [110]
1200(48)	○	○	○	0.75 {7.7} [110]

DIMENSIONS TABLE

Nominal Size		d	JIS 10K						JWWA						D	D ₁	D ₂	L	H	I	H ₁	H ₂	A	A ₂	A ₄	A ₅	A ₆	Gear box Model No.				
mm	inch		C	h	N	n	n ₁		M	B	C	h	N	n															n ₁		M	B
						/side	/total					/side	/total																			
700	28	670	840	33	24	20	4	8	M30	35	854	33	16	16	—	—	—	—	928	760	350	206	685	897	589	590	194	286	158	403	296	BRL-10
800	32	770	950	33	28	24	4	8	M30	35	960	33	20	16	4	8	M30	35	1034	870	350	240	715	927	619	620	194	286	158	403	296	BRL-10
900	36	870	1050	33	28	24	4	8	M30	35	1073	33	20	16	4	8	M30	35	1168	978	350	240	800	1112	704	705	194	286	158	403	296	BRL-10
1000	40	970	1160	39	28	24	4	8	M36	35	1179	33	24	20	4	8	M30	35	1262	1080	460	300	845	1157	749	750	229	242	210	565	323	BRL-20
1100	44	1080	1270	39	28	24	4	8	M36	42	1283	33	24	20	4	8	M30	35	1380	1195	460	300	942	1260	780	840	229	242	210	565	323	BRL-20
1200	48	1170	1380	39	32	28	4	8	M36	42	1387	33	28	24	4	8	M30	35	1488	1300	460	350	992	1310	850	890	229	242	210	565	323	BRL-20

Nominal Size		d	DIN PN 10						D	D ₁	D ₂	L	H	I	H ₁	H ₂	A	A ₂	A ₄	A ₅	A ₆	Gear box Model No.		
mm	inch		C	h	N	n	n ₁																M	B
						/side	/total																	
700	28	670	840	33	24	20	4	8	M27	35	928	760	350	206	685	897	589	590	194	286	158	403	296	BRL-10
800	32	770	950	33	28	20	4	8	M30	35	1034	870	350	240	715	927	619	620	194	286	158	403	296	BRL-10
900	36	870	1050	33	28	24	4	8	M30	35	1168	978	350	240	800	1112	704	705	194	286	158	403	296	BRL-10
1000	40	970	1160	39	28	24	4	8	M33	42	1262	1080	460	300	845	1157	749	750	229	242	210	565	323	BRL-20
1200	48	1170	1380	39	32	28	4	8	M36	42	1488	1300	460	350	992	1310	850	890	229	242	210	565	323	BRL-20

Nominal Size		d	ANSI Class 125						ANSI Class 150						D	D ₁	D ₂	L	H	I	H ₁	H ₂	A	A ₂	A ₄	A ₅	A ₆	Gear box Model No.				
mm	inch		C	h	N	n	n ₁		M	B	C	h	N	n															n ₁		M	B
						/side	/total					/side	/total																			
700	28	26.38	—	—	—	—	—	—	—	34.00	1.38	28	24	4	8	1 1/4	1.38	36.54	29.92	17.13	8.11	29.41	37.99	23.19	23.23	7.64	11.26	6.22	15.87	11.65	BRL-10	
800	32	30.31	—	—	—	—	—	—	—	38.50	1.62	28	24	4	8	1 1/2	1.38	41.34	34.25	17.13	9.45	30.59	39.17	24.37	24.41	7.64	11.26	6.22	15.87	11.65	BRL-10	
900	36	34.25	47.25	1.62	36	32	4	8	1 1/2	1.38	—	—	—	—	—	—	—	45.98	38.50	25.00	9.45	33.94	46.46	27.72	27.76	7.64	11.26	6.22	15.87	11.65	BRL-10	
1000	40	38.19	—	—	—	—	—	—	—	47.25	1.62	36	32	4	8	1 1/2	1.38	50.00	42.52	25.00	11.81	36.30	48.82	29.49	29.53	9.02	9.53	8.27	22.24	12.72	BRL-20	
1100	44	42.52	—	—	—	—	—	—	—	51.75	1.62	40	36	4	8	1 1/2	1.77	54.33	47.05	25.00	11.81	39.84	52.36	30.71	33.07	9.02	9.53	8.27	22.24	12.72	BRL-20	
1200	48	46.06	56.00	1.62	44	40	4	8	1 1/2	1.77	56.00	1.62	44	40	4	8	1 1/2	1.77	58.58	51.18	25.00	13.78	41.81	54.33	33.46	35.04	9.02	9.53	8.27	22.24	12.72	BRL-20

Nominal Size mm(inch)	700(28)	800(32)	900(36)	1000(40)	1100(44)	1200(48)
Stem Torque N·m {kgf·cm}	4,500 {45,900}	5,900 {60,200}	7,500 {76,500}	10,200 {104,000}	13,000 {132,600}	15,000 {153,000}
Hand Wheel operating force N{kgf}	339 {35}	444 {45}	565 {58}	326 {33}	415 {42}	479 {49}
Number of Handle Rotation	60	60	60	137	137	137
Gear Box Model	BRL-10	BRL-10	BRL-10	BRL-20	BRL-20	BRL-20